

Tepelné čerpadlo pro ohřev TUV k vnitřní instalaci

230V



Označení		WH20S.F5	WH27S.F5
Objem nádrže	(l)	200	270
Energetická účinnost COP	vzduch 7°C, s potrubím	3.3	3.45
	vzduch 15°C, bez potrubí	3.5	3.85
Denní spotřeba energie	kWh (15°C)	3.33	3.1
Roční spotřeba energie	kWh (7°C / 15°C)	756 / 709	712 / 646
El.příkon (spodní / horní top.těleso 230V)	(kW)	2 / 2	
El.příkon - tepelné čerpadlo	(kW)	0.5	
Max.el.příkon	(kW)	2.5	
Třída energet.účinnosti		A+ / A+	A+ / A++
Napájení	(fáze, V, Hz)	1f, 220-240, 50	
Rozsah napájení	(V)	195 ~ 265	
Doporučené jistění	(A)	16	
Průtok vzduchu	vys / níz (m3/min)	6.7 / 4.4	
Akustický tlak	ve 2 m (dBA)	38 (automatický režim) / 41 (turbo režim)	
Akustický výkon	(dBA)	55	
Rozměry	Š*V*H (mm)	580*1625*582	580*2008*582
Hmotnost	(kg)	100	119
Provozní rozsah	(°C such.tepl.)	-5 ~ 48	
Barva jednotky		RAL 9006 (bílý hliník - metalíza)	
Kompresor		invertorový dvojitý rotační	
Max.pracovní tlak nádrže	(kPa)	1034	
Napojení kondenzátu (vnitřní průměr)	(mm)	19, 12.7	
Typ chladiva		R134a	
Náplň chladiva	(g)	650	750
GWP (potenciál globálního oteplování)		1430	
Ekvivalent CO ₂	t-CO ₂ eq	0,93	1,073
Napojení vody	(coul)	3/4 vnější závit	
Ceníková cena bez DPH a PHE		60 452 CZK	63 252 CZK

Testovací podmínky jsou dle EN16147 a EN12202

Tepelné čerpadlo pro ohřev TUV

Výkonové tabulky - automatický režim

WH20S.F5

Water Tank Setting Temp. °C DB	Ambient Temp. °C DB	Initial Water Tank Temperature : °C DB														
		10			20			30			40			50		
		RT	COP	PI	RT	COP	PI	RT	COP	PI	RT	COP	PI	RT	COP	PI
35	-5	4.10	1.59	3.67	3.03	5.37	0.65	-	-							
	20	3.86	1.60	3.65	2.76	5.40	0.65	-	-							
	48	3.01	1.69	3.45	1.78	7.26	0.48	-	-							
40	-5	4.59	1.50	4.68	4.20	5.17	0.90	1.87	5.81	0.40	-	-				
	20	4.34	1.50	4.66	3.82	5.20	0.90	1.70	5.85	0.40	-	-				
	48	3.46	1.59	4.39	2.47	7.00	0.67	1.10	7.87	0.30	-	-				
45	-5	5.08	1.43	5.69	4.10	1.59	3.67	3.03	5.37	0.65	-	-				
	20	4.82	1.44	5.66	3.86	1.60	3.65	2.76	5.40	0.65	-	-				
	48	3.91	1.53	5.33	3.01	1.69	3.45	1.78	7.26	0.48	-	-				
50	-5	5.56	1.39	6.71	4.59	1.50	4.68	4.20	5.17	0.90	1.87	5.81	0.40	-	-	-
	20	5.30	1.40	6.66	4.34	1.50	4.66	3.82	5.20	0.90	1.70	5.85	0.40	-	-	-
	48	4.36	1.49	6.27	3.46	1.59	4.39	2.47	7.00	0.67	1.10	7.87	0.30	-	-	-
55	-5	5.76	1.28	8.18	4.78	1.33	6.15	3.81	1.41	4.12	2.84	1.67	2.10	-	-	-
	20	5.78	1.37	7.67	4.82	1.44	5.66	3.86	1.60	3.65	2.76	5.40	0.65	-	-	-
	48	4.81	1.46	7.21	3.91	1.53	5.33	3.01	1.69	3.45	1.78	7.26	0.48	-	-	-
60	-5	6.01	1.15	10.19	5.04	1.14	8.16	4.06	1.14	6.13	3.09	1.14	4.10	0.93	1.25	1.87
	20	6.26	1.35	8.67	5.30	1.40	6.66	4.34	1.50	4.66	3.82	5.20	0.90	1.70	5.85	0.40
	48	5.26	1.43	8.15	4.36	1.49	6.27	3.46	1.59	4.39	2.47	7.00	0.67	1.10	7.87	0.30

WH27S.F5

Water Tank Setting Temp. °C DB	Ambient Temp. °C DB	Initial Water Tank Temperature : °C DB														
		10			20			30			40			50		
		RT	COP	PI	RT	COP	PI	RT	COP	PI	RT	COP	PI	RT	COP	PI
35	-5	5.54	1.59	4.95	3.94	5.37	0.88	-	-							
	20	5.22	1.60	4.93	3.58	5.40	0.87	-	-							
	48	4.06	1.69	4.66	2.32	7.26	0.65	-	-							
40	-5	6.20	1.50	6.32	5.51	5.17	1.22	2.36	5.81	0.54	-	-				
	20	5.86	1.50	6.29	5.01	5.20	1.21	2.15	5.85	0.54	-	-				
	48	4.67	1.59	5.93	3.24	7.00	0.90	1.39	7.87	0.40	-	-				
45	-5	6.85	1.43	7.69	5.07	1.59	4.95	3.94	5.37	0.88	-	-				
	20	6.01	1.44	7.64	4.71	1.60	4.93	3.58	5.40	0.87	-	-				
	48	4.62	1.53	7.20	3.41	1.69	4.66	2.32	7.26	0.65	-	-				
50	-5	7.51	1.39	9.06	6.20	1.50	6.32	5.51	5.17	1.22	2.36	5.81	0.54	-	-	-
	20	7.16	1.40	9.00	5.86	1.50	6.29	5.01	5.20	1.21	2.15	5.85	0.54	-	-	-
	48	5.88	1.49	8.47	4.67	1.59	5.93	3.24	7.00	0.90	1.39	7.87	0.40	-	-	-
55	-5	7.77	1.28	11.04	6.46	1.33	8.30	5.15	1.41	5.57	3.83	1.67	2.83	-	-	-
	20	7.81	1.37	10.35	6.51	1.44	7.64	5.22	1.60	4.93	3.58	5.40	0.87	-	-	-
	48	6.49	1.46	9.74	5.28	1.53	7.20	4.06	1.69	4.66	2.32	7.26	0.65	-	-	-
60	-5	8.11	1.15	13.75	6.80	1.14	11.01	5.49	1.14	8.27	4.17	1.14	5.54	1.26	1.25	2.52
	20	8.45	1.35	11.71	7.16	1.40	9.00	5.86	1.50	6.29	5.01	5.20	1.21	2.15	5.85	0.54
	48	7.10	1.43	11.01	5.88	1.49	8.47	4.67	1.59	5.93	3.24	7.00	0.90	1.39	7.87	0.40

Water Tank Setting Temp. °C DB - nastavená teplota vodní nádrže °C suchý teploměr

Ambient Temp. °C DB - okolní teplota °C suchý teploměr

Initial Water Tank Temp. °C DB - počáteční teplota ve vodní nádrži °C suchý teploměr

RT: Recovery time - čas dohřevu (h)

PI: el.příkon (kWh)

COP: koeficient výkonu ku příkonu

	Provoz tepelného čerpadla
	Provoz tepelného čerpadla a dohřevu
	Pouze dohřev

Tepelné čerpadlo pro ohřev TUV

Výkonové tabulky - režim tepelného čerpadla

WH20S.F5

Water Tank Setting Temp. °C DB	Ambient Temp. °C DB	Initial Water Tank Temperature : °C DB														
		10			20			30			40			50		
		RT	COP	PI	RT	COP	PI	RT	COP	PI	RT	COP	PI	RT	COP	PI
35	-5	5.37	2.53	2.31	3.03	2.68	1.30	-	-	-	-	-	-	-	-	-
	20	2.82	4.39	1.33	1.60	4.66	0.75	-	-	-	-	-	-	-	-	-
	48	1.63	6.64	0.88	0.92	7.05	0.50	-	-	-	-	-	-	-	-	-
40	-5	6.53	2.49	2.81	4.20	2.58	1.81	1.87	2.91	0.80	-	-	-	-	-	-
	20	3.44	4.33	1.62	2.21	4.49	1.04	0.98	5.05	0.46	-	-	-	-	-	-
	48	1.98	6.55	1.07	1.27	6.79	0.69	0.57	7.64	0.31	-	-	-	-	-	-
45	-5	7.70	2.47	3.31	5.37	2.53	2.31	3.03	2.68	1.30	-	-	-	-	-	-
	20	4.05	4.29	1.90	2.82	4.39	1.33	1.60	4.66	0.75	-	-	-	-	-	-
	48	2.33	6.48	1.26	1.63	6.64	0.88	0.92	7.05	0.50	-	-	-	-	-	-
50	-5	8.87	2.45	3.81	6.53	2.49	2.81	4.20	2.58	1.81	1.87	2.91	0.80	-	-	-
	20	4.67	4.26	2.19	3.44	4.33	1.62	2.21	4.49	1.04	0.98	5.05	0.46	-	-	-
	48	2.69	6.43	1.45	1.98	6.55	1.07	1.27	6.79	0.69	0.57	7.64	0.31	-	-	-
55	-5	9.68	2.23	4.71	7.35	2.20	3.71	5.02	2.16	2.71	2.68	2.05	1.70	-	-	-
	20	5.28	4.23	2.48	4.05	4.29	1.90	2.82	4.39	1.33	1.60	4.66	0.75	-	-	-
	48	3.04	6.40	1.64	2.33	6.48	1.26	1.63	6.64	0.88	0.92	7.05	0.50	-	-	-
60	-5	10.27	1.98	5.88	7.93	1.91	4.88	5.60	1.81	3.87	3.27	1.63	2.87	0.93	1.25	1.87
	20	5.89	4.21	2.77	4.67	4.26	2.19	3.44	4.33	1.62	2.21	4.49	1.04	0.98	5.05	0.46
	48	3.39	6.37	1.83	2.69	6.43	1.45	1.98	6.55	1.07	1.27	6.79	0.69	0.57	7.64	0.31

WH27S.F5

Water Tank Setting Temp. °C DB	Ambient Temp. °C DB	Initial Water Tank Temperature : °C DB														
		10			20			30			40			50		
		RT	COP	PI	RT	COP	PI	RT	COP	PI	RT	COP	PI	RT	COP	PI
35	-5	7.25	2.53	3.12	4.10	2.68	1.76	-	-	-	-	-	-	-	-	-
	20	3.81	4.39	1.79	2.16	4.66	1.01	-	-	-	-	-	-	-	-	-
	48	2.20	6.64	1.19	1.24	7.05	0.67	-	-	-	-	-	-	-	-	-
40	-5	8.82	2.49	3.79	5.67	2.58	2.44	2.52	2.91	1.08	-	-	-	-	-	-
	20	4.64	4.33	2.18	2.98	4.49	1.40	1.33	5.05	0.62	-	-	-	-	-	-
	48	2.67	6.55	1.44	1.72	6.79	0.93	0.76	7.64	0.41	-	-	-	-	-	-
45	-5	10.40	2.47	4.47	7.25	2.53	3.12	4.10	2.68	1.76	-	-	-	-	-	-
	20	5.47	4.29	2.57	3.81	4.39	1.79	2.16	4.66	1.01	-	-	-	-	-	-
	48	3.15	6.48	1.70	2.20	6.64	1.19	1.24	7.05	0.67	-	-	-	-	-	-
50	-5	11.81	2.48	5.08	8.66	2.54	3.72	5.51	2.66	2.37	2.36	3.10	1.02	-	-	-
	20	6.22	4.31	2.92	4.56	4.41	2.14	2.90	4.62	1.36	1.24	5.39	0.58	-	-	-
	48	3.58	6.52	1.93	2.63	6.67	1.42	1.67	6.98	0.90	0.72	8.15	0.39	-	-	-
55	-5	13.07	2.23	6.36	9.92	2.20	5.01	6.77	2.16	3.65	3.62	2.05	2.30	-	-	-
	20	7.05	4.28	3.31	5.39	4.35	2.53	3.73	4.49	1.75	2.07	4.85	0.97	-	-	-
	48	4.06	6.47	2.19	3.10	6.58	1.68	2.15	6.79	1.16	1.19	7.33	0.64	-	-	-
60	-5	13.86	1.98	7.94	10.71	1.91	6.58	7.56	1.81	5.23	4.41	1.63	3.87	1.26	1.25	2.52
	20	7.88	4.26	3.70	6.22	4.31	2.92	4.56	4.41	2.14	2.90	4.62	1.36	1.24	5.39	0.58
	48	4.53	6.43	2.45	3.58	6.52	1.93	2.63	6.67	1.42	1.67	6.98	0.90	0.72	8.15	0.39

Water Tank Setting Temp. °C DB - nastavená teplota vodní nádrže °C suchý teploměr

Ambient Temp. °C DB - okolní teplota °C suchý teploměr

Initial Water Tank Temp. °C DB - počáteční teplota ve vodní nádrži °C suchý teploměr

RT: Recovery time - čas dohřevu (h)

PI: el.příkon (kWh)

COP: koeficient výkonu ku příkonu

	Provoz tepelného čerpadla
	Provoz tepelného čerpadla a dohřevu
	Pouze dohřev

Tepelné čerpadlo pro ohřev TUV

Výkonové tabulky - turbo režim

WH20S.F5

Water Tank Setting Temp. °C DB	Ambient Temp. °C DB	Initial Water Tank Temperature : °C DB														
		10			20			30			40			50		
		RT	COP	PI	RT	COP	PI	RT	COP	PI	RT	COP	PI	RT	COP	PI
35	-5	3.78	1.38	4.22	2.81	1.66	2.11	-	-							
	20	2.66	1.60	3.65	1.78	2.01	1.74	-	-							
	48	2.10	1.76	3.32	1.30	2.20	1.59	-	-							
40	-5	4.27	1.33	5.27	3.30	1.48	3.16	1.87	2.91	0.80	-	-				
	20	3.10	1.52	4.60	2.22	1.73	2.70	0.98	5.05	0.46	-	-				
	48	2.50	1.67	4.18	1.70	1.90	2.46	0.57	7.64	0.31	-	-				
45	-5	4.75	1.29	6.33	3.78	0.96	6.05	2.81	2.18	1.60	-	-				
	20	3.54	1.47	5.55	2.66	1.27	4.59	1.78	2.41	1.45	-	-				
	48	2.91	1.62	5.04	2.10	1.52	3.83	1.30	2.50	1.40	-	-				
50	-5	5.24	1.26	7.39	4.27	1.33	5.27	3.30	1.48	3.16	1.87	2.91	0.80	-	-	-
	20	3.98	1.43	6.51	3.10	1.52	4.60	2.22	1.73	2.70	0.98	5.05	0.46	-	-	-
	48	3.31	1.58	5.91	2.50	1.67	4.18	1.70	1.90	2.46	0.57	7.64	0.31	-	-	-
55	-5	5.76	1.19	8.82	4.78	1.22	6.70	3.81	1.27	4.59	2.84	1.41	2.48	-	-	-
	20	4.43	1.41	7.46	3.54	1.47	5.55	2.66	1.60	3.65	1.78	2.01	1.74	-	-	-
	48	3.71	1.55	6.77	2.91	1.62	5.04	2.10	1.76	3.32	1.30	2.20	1.59	-	-	-
60	-5	6.01	1.09	10.69	5.04	1.09	8.58	4.06	1.08	6.46	3.09	1.07	4.35	0.93	1.25	1.87
	20	4.87	1.40	8.33	3.98	1.45	6.43	3.10	1.54	4.54	2.22	1.76	2.64	0.98	5.05	0.46
	48	4.11	1.55	7.53	3.31	1.60	5.82	2.50	1.70	4.11	1.70	1.94	2.40	0.57	7.64	0.31

WH27S.F5

Water Tank Setting Temp. °C DB	Ambient Temp. °C DB	Initial Water Tank Temperature : °C DB														
		10			20			30			40			50		
		RT	COP	PI	RT	COP	PI	RT	COP	PI	RT	COP	PI	RT	COP	PI
35	-5	5.11	1.38	5.69	3.79	1.66	2.84	-	-							
	20	3.59	1.60	4.92	2.40	2.01	2.35	-	-							
	48	2.84	1.76	4.48	1.75	2.20	2.15	-	-							
40	-5	5.76	1.33	7.12	4.45	3.77	1.67	2.52	2.91	1.08	-	-				
	20	4.19	1.52	6.21	3.00	6.06	1.04	1.33	5.05	0.62	-	-				
	48	3.38	1.67	5.64	2.30	8.80	0.72	0.76	7.64	0.41	-	-				
45	-5	6.42	1.29	8.54	5.11	1.38	5.69	3.79	1.66	2.84	-	-				
	20	4.78	1.47	7.50	3.59	1.60	4.92	2.40	2.01	2.35	-	-				
	48	3.92	1.62	6.81	2.84	1.76	4.48	1.75	2.20	2.15	-	-				
50	-5	7.07	1.26	9.97	5.76	1.33	7.12	4.45	1.48	4.27	2.36	3.10	1.02	-	-	-
	20	5.38	1.43	8.78	4.19	1.52	6.21	3.00	1.73	3.64	1.24	5.39	0.58	-	-	-
	48	4.46	1.58	7.97	3.38	1.67	5.64	2.30	1.90	3.31	0.72	8.15	0.39	-	-	-
55	-5	7.34	1.20	11.84	6.02	1.23	8.99	4.71	1.28	6.14	3.40	1.44	3.29	-	-	-
	20	5.97	1.41	10.07	4.78	1.47	7.50	3.59	1.60	4.92	2.40	2.01	2.35	-	-	-
	48	5.01	1.55	9.14	3.92	1.62	6.81	2.84	1.76	4.48	1.75	2.20	2.15	-	-	-
60	-5	7.68	1.10	14.37	6.37	1.09	11.52	5.05	1.09	8.67	3.74	1.08	5.82	1.26	1.25	2.52
	20	6.57	1.39	11.36	5.38	1.43	8.78	4.19	1.52	6.21	3.00	1.73	3.64	1.24	5.39	0.58
	48	5.55	1.53	10.30	4.46	1.58	7.97	3.38	1.67	5.64	2.30	1.90	3.31	0.72	8.15	0.39

Water Tank Setting Temp. °C DB - nastavená teplota vodní nádrže °C suchý teploměr

Ambient Temp. °C DB - okolní teplota °C suchý teploměr

Initial Water Tank Temp. °C DB - počáteční teplota ve vodní nádrži °C suchý teploměr

RT: Recovery time - čas dohřevu (h)

PI: el.příkon (kWh)

COP: koeficient výkonu ku příkonu

	Provoz tepelného čerpadla
	Provoz tepelného čerpadla a dohřevu
	Pouze dohřev

Rychlost změny času dohřevu v závislosti na délce potrubí

Model	CASE	Mode	Duct Length										
			No Duct	1m	2m	3m	4m	5m	6m	7m	8m	9m	10m
WH20S.F5(R5TT20F-SA1) WH27S.F5(R5TT27F-SA0)	1	Heat Pump	100	118	125	128	129	131	133	136	136	137	139
WH20S.F5(R5TT20F-SA1) WH27S.F5(R5TT27F-SA0)	3	Auto	100	101	103	104	105	106	108	109	110	112	113

Case (případ) 1 a 3 jsou blíže popsány na následující straně

Tepelné čerpadlo pro ohřev TUV

Instalace - maximální délka potrubí

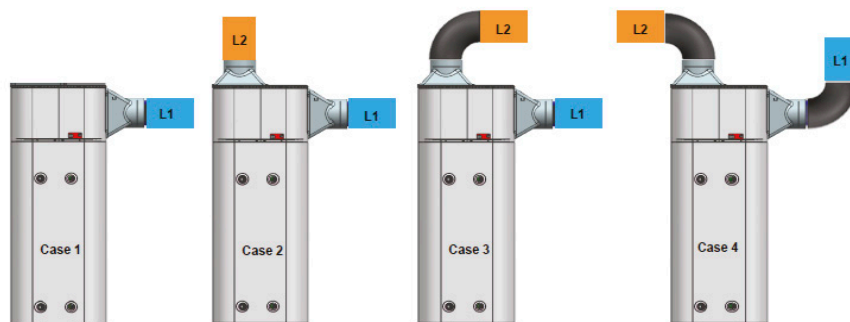

Model	Případ (Case)	1		2		3		4	
	Průměr potrubí	Ø200	Ø160	Ø200	Ø160	Ø200	Ø160	Ø200	Ø160
WH20S.F5	Max. délka (m)	62	25	55	22	52	19	49	16
WH27S.F5									

Max.délka = délka sacího potrubí (L1) + délka výfukového potrubí (L2)

Instalace - povolená délka potrubí a statický tlak

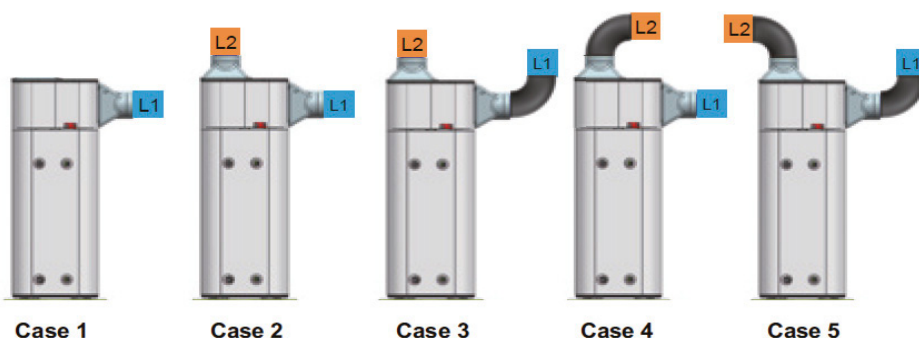

Statický tlak systému		Případ (Case)	1		2		3	
1150 ot/min	tlak (Pa)	Průměr potrubí	Ø200	Ø160	Ø200	Ø160	Ø200	Ø160
		Poznámka	Pouze výfuk		Bez kolen		1 koleno	
3,6 m ³ /min	55	L1+L2	62	25	55	22	52	19
4,5 m ³ /min	43	(m)	31	12	27	10	24	7

Statický tlak systému		Případ (Case)	4		5	
1150 ot/min	tlak (Pa)	Průměr potrubí	Ø200	Ø160	Ø200	Ø160
		Poznámka	1 koleno		2 kolena	
3,6 m ³ /min	55	L1+L2	52	19	49	16
4,5 m ³ /min	43	(m)	24	7	21	4

Celkový statický tlak nesmí překročit hodnotu 55 Pa.

Kalkulace statického tlaku

3,6 m ³ /min			
Komponent	Rovné potrubí PVC potrubí (Pa/m)	Rovné potrubí 90° PVC koleno (Pa/m)	Potrubní nástavec Sací a výfuk.sada (Pa)
Ø160	2	6	
Ø200	0,8	2,3	
Nástavec			5,5 + 5,5

4,5 m ³ /min			
Komponent	Rovné potrubí PVC potrubí (Pa/m)	Rovné potrubí 90° PVC koleno (Pa/m)	Potrubní nástavec Sací a výfuk.sada (Pa)
Ø160	3,1	9,4	
Ø200	1,2	3,7	
Nástavec			5,8 + 5,8

Tepelné čerpadlo pro ohřev TUV

Schema zařízení

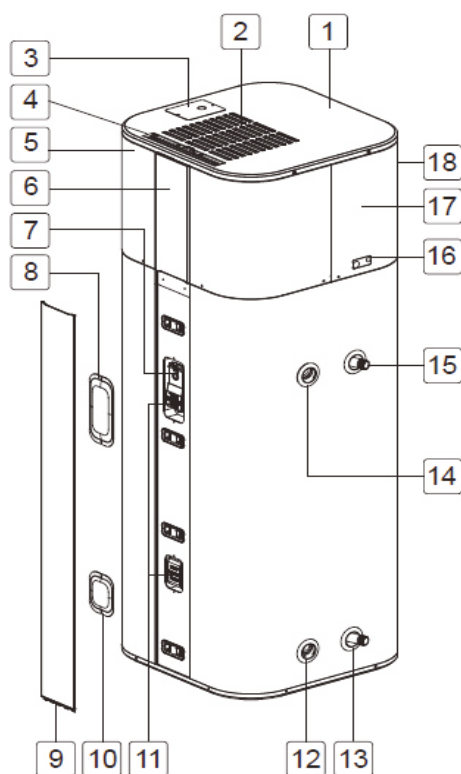

- 1 Horní kryt
- 2 Ventilační otvor - přívod
- 3 Elektrická skříň
- 4 Filtr
- 5 Čelní panel
- 6 Displej, řídicí panel
- 7 ECO
- 8 Kryt horního prvku
- 9 Přední dekor
- 10 Kryt spodního prvku
- 11 Topné těleso
- 12 Otvor pro kondenzátní ventil
- 13 Vstup vody
- 14 Otvor pro pojistný ventil teploty a tlaku
- 15 Výstup vody
- 16 Odvod kondenzátu
- 17 Zadní panel
- 18 Ventilační otvor - odvod

Servisní prostor

bez napojení potrubí

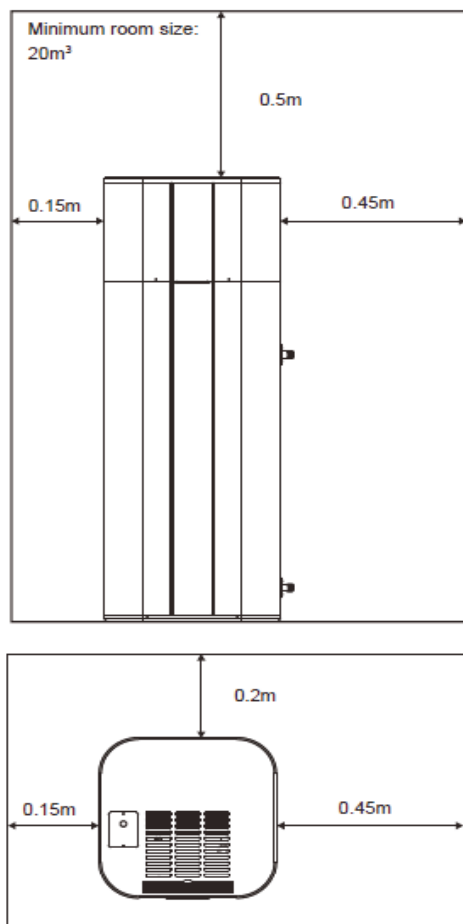

se sacím potrubím

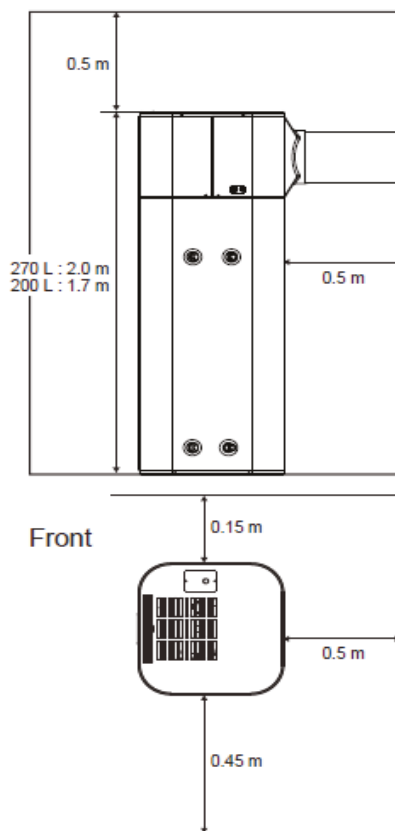

se sacím i výfukovým potrubím

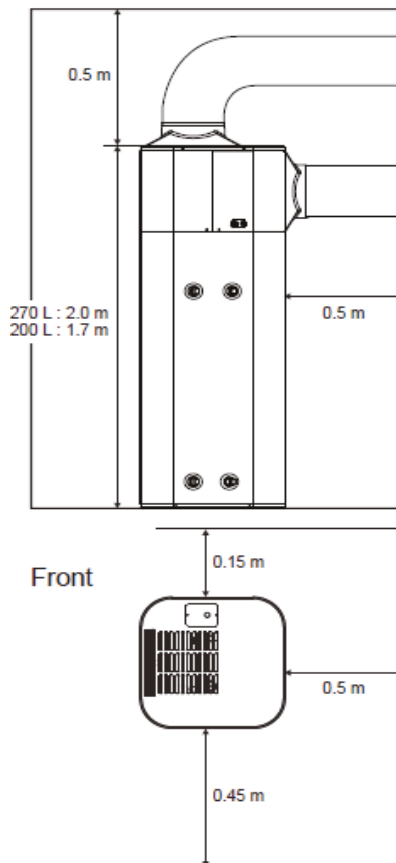

Minimální objem místnosti: 20 m³

Tepelné čerpadlo pro ohřev TUV - WH20S

Unit : mm

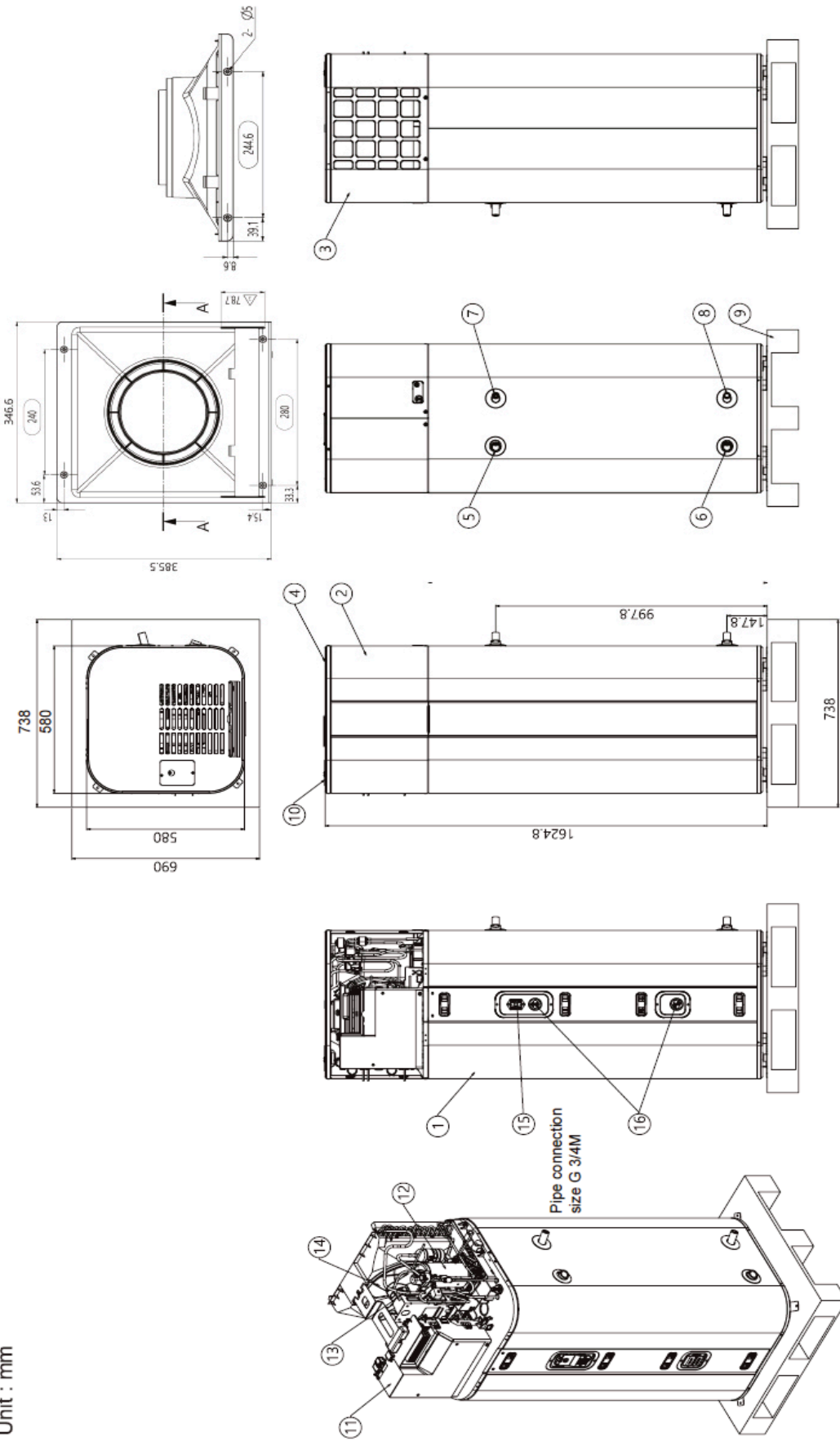

Part No.	Part Name	Description
16	Heater	25A, 5000W, 240V
15	ECO	Emergency Cut Off(7%)
14	Fan Propeller	290 P.
13	Motor	45W
12	Compressor	ES1952MBA
11	C/Box Case	-
10	Junction cover	Power Input
9	Wooden pallet	-
8	Inlet Pipe	Water In, 3/4 NPT
7	Outlet Pipe	Water Out, 3/4 NPT
6	Drain Valve	3/4 NPT
5	1/P Valve	210°F/99°C, 3/4 NPT
4	Top Cover	-
3	Rear Panel	-
	Front Panel	-
	Water tank	200L
	Part Name	Description

Tepelné čerpadlo pro ohřev TUV - WH27S

